

MASTER TEST GAUGE ACCURACY 0.2%



Budenberg Standard Test Gauges are generally recognised as a world leader for accuracy and quality and are used by many Calibration Laboratories and workshops worldwide. The 5314 now provides a higher specification and incorporates many additional features as standard.

Housed in a new die cast safety pattern case, the 5314 meets the full requirements of EN837 including a brighter anti-parallax mirror scale & knife edge pointer for accurate repeatable readings. Recalibration is simplified by inclusion of a micrometer adjustable pointer and printed calibration marks on the dials.

All units are supplied with a detailed calibration certificate which is traceable to National Standards.



Sizes

250mm dial diameter

Mounting

Direct, Surface Mounting
Flush Panel Mounting with clamp or three hole fixing

Case

LM6M Aluminium casting to BS1490 utilising a full Safety Pattern solid baffle wall with blow out back, finish to BS381C

Bezel

Direct / Surface mount - Stainless Steel 316L polished.
Flush mount - Die cast Aluminium finished in black.

Scale Ranges

0 to 600 mBar up to 0 to 2500 Bar Pressure
Equivalent units of Pressure / Vacuum Available
Dual Scale units or custom scales can be provided

Pressure Element

Up to 70 Bar Beryllium Copper bourdon tube & Brass Chrome plated connection
From 71 Bar up to 600 Bar Beryllium Copper coil tube & Brass Chrome plated connection
From 601 Bar up to 2500 Bar Ni-Span C Coil & Stainless Steel connection
Option for Stainless Steel on request.

Overload

Units will withstand the following overload pressure conditions for a short period:

Max Scale Value	Over Pressure to be Applied
≤ 80 Bar	130% of Maximum Scale Value
≥ 81 to 100 Bar	120% of Maximum Scale Value
≥ 601 Bar	115% of Maximum Scale Value

Pressure Connection

1/2" BSP or NPT
3/8" BSP or 1/2" NPT as Standard on Flush Mounting Units
Other connections including HF2 high pressure are available
contact our Sales Office for Details

Accuracy Class

0.2% of FSD as defined in EN837-1

Dial

White anodised Aluminium with Mirror Scale with Anti Parallax mirror scale for accurate reading.
Option: Dual scales or special dial markings are available

Pointer

Micrometer Adjustable, Knife-edge, Stainless Steel coloured Black

Movement

Non Ferrous with Glass Bearings for Improved Accuracy & Sensitivity

Window

Safety window

Environmental Rating

Dust Proof and Splash Proof to IP54

Temperature

Operating: -20 to +60 Degrees C
Storage: -40 up to + 70 Degrees C
Options: For lower or higher operating temperatures, please contact our Sales Office.

Certification

All instruments are individually calibrated and have an unique Serial Number printed on the dial. A Certificate of Conformity traceable to National Standards is supplied free of charge.

Calibration

All units are individually calibrated to suit the test medium being used i.e. Gas or Liquid. It is important therefore to specify the medium at time of order

Safety

All units are manufactured to comply with EN 837-1, to S1 specification and other regulatory standards including P.E.D.

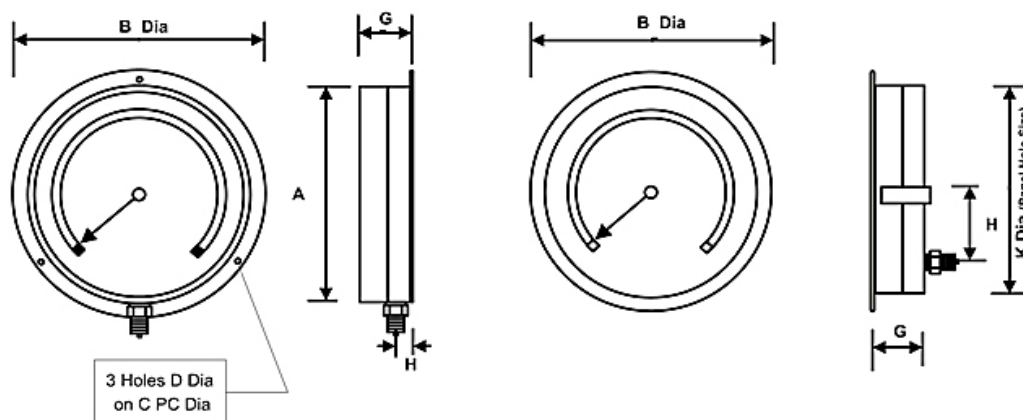

Direct / Surface Mounting

Flush Clamp Mounting

Model No	A	B	C	D	G	H	K	Weight
250mm 5314 Surface Mounting	259mm	290mm	273mm	6.4mm	66mm	20mm		2.9 Kg
250mm 5314 Flush Mounting	283mm				90mm	80mm	270mm	2.3 Kg

Options

Oil free Test Gauges are available, the tubes and blocks of the Model 5314 are vapour de-greased before assembly and the strictest precautions are taken to see that no oil enters the tube during manufacture, the dial is marked "Use No Oil".

UKAS traceable certification available on request.

Accessories

For high temperature applications such as steam, see our range of syphons and adaptors. – See separate Datasheet.

We can supply Needle, Ball or 2 Valve manifolds for the Model 5314 – See separate Datasheet.

The manifolds in addition to allowing the instrument to operate normally allows the following: -

- a). Checking of gauge zero at line pressure.
- b). Complete isolation of the instrument.
- c). Inline calibration, allows in situation calibration

Applications

- a) Calibration of pressure gauges, transducers and transmitters.
- b) Calibration of pneumatic controllers, valves etc.
- c) Measurement of pressure on test beds in Aero, hydraulic systems, diesel engine injection systems.
- d) Setting of pressure relief valves.
- e) Measurement of pore water pressure in soil mechanics laboratories.
- f) Efficiency testing of steam turbines in power stations, gas turbines and compressors.

Specifications and dimensions in this leaflet, are subject to change without prior notice.

Budenberg Gauge Co Ltd
 4 Gilchrist Road. Northbank Industrial Park. Irlam. Manchester. M44 5AY.
 Tel : +44 (0)870 442 5441. Fax : +44 (0)870 787 7350.
 Email : sales@budenberg.co.uk Web: www.budenberginstruments.com